

Preliminary Specifications

Final Specifications

<b>Module</b>	8.4 Inch Color TFT-LCD
<b>Model Name</b>	G084SN03 V1

<b>Customer</b>	<b>Date</b>
<b>Checked &amp; Approved by</b>	
_____	_____
<p>Note: This Specification is subject to change without notice.</p>	

<b>Approved by</b>	<b>Date</b>
_____ Debbie Chiu	_____ 2008/1/14
<b>Prepared by</b>	
_____ ALEX Cheng	_____ 2008/1/14
<p>General Display Business Division / AU Optronics corporation</p>	

## Contents

<b>1. Operating Precautions .....</b>	<b>4</b>
<b>2. General Description .....</b>	<b>5</b>
2.1 Display Characteristics .....	5
2.2 Optical Characteristics .....	6
<b>3. Functional Block Diagram .....</b>	<b>9</b>
<b>4. Absolute Maximum Ratings.....</b>	<b>10</b>
4.1 Absolute Ratings of TFT LCD Module.....	10
4.2 Absolute Ratings of Environment.....	10
<b>5. Electrical Characteristics.....</b>	<b>11</b>
5.1 TFT LCD Module .....	11
5.2 Backlight Unit .....	13
<b>6. Signal Characteristic.....</b>	<b>15</b>
6.1 Pixel Format Image.....	15
6.2 Scanning Direction.....	16
6.3 Signal Description .....	17
6.4 The Input Data Format.....	18
6.5 Interface Timing .....	19
6.6 Power ON/OFF Sequence .....	20
<b>7. Connector &amp; Pin Assignment .....</b>	<b>21</b>
7.1 TFT LCD Module: LVDS Connector.....	21
7.2 Backlight Unit: Lamp Connector .....	21
7.3 Lamp Connector Pin Assignment.....	21
<b>8. Reliability Test Criteria.....</b>	<b>22</b>
<b>9. Mechanical Characteristics .....</b>	<b>23</b>
9.1 LCM Front View .....	23
9.2 LCM Rear View .....	234
<b>10. Label and Packaging.....</b>	<b>25</b>
10.1 Shipping Label (on the rear side of TFT-LCD display) .....	25
10.2 Carton Package .....	25
<b>11 Safety.....</b>	<b>26</b>
11.1 Sharp Edge Requirements.....	26
11.2 Materials.....	26
11.3 Capacitors .....	26
11.4 National Test Lab Requirement.....	26

**Record of Revision**

<b>Version and Date</b>	<b>Page</b>	<b>Old description</b>	<b>New Description</b>
0.0 2008/1/3	All	First Edition	
0.1 2008/1/14	6	Viewing Angle 70/70/65/55(R/L/U/D)	Viewing Angle 75/75/75/75(R/L/U/D)
	24		9.2 LCM Rear View-Connector Illustration

## 1. Operating Precautions

- 1) Since front polarizer is easily damaged, please be cautious and not to scratch it.
- 2) Be sure to turn off power supply when inserting or disconnecting from input connector.
- 3) Wipe off water drop immediately. Long contact with water may cause discoloration or spots.
- 4) When the panel surface is soiled, wipe it with absorbent cotton or soft cloth.
- 5) Since the panel is made of glass, it may be broken or cracked if dropped or bumped on hard surface.
- 6) Since CMOS LSI is used in this module, take care of static electricity and insure human earth when handling.
- 7) Do not open nor modify the module assembly.
- 8) Do not press the reflector sheet at the back of the module to any direction.
- 9) In case if a module has to be put back into the packing container slot after it was taken out from the container, do not press the center of the CCFL Reflector edge. Instead, press at the far ends of the CFL Reflector edge softly. Otherwise the TFT Module may be damaged.
- 10) At the insertion or removal of the Signal Interface Connector, be sure not to rotate nor tilt the Interface Connector of the TFT Module.
- 11) After installation of the TFT Module into an enclosure (Notebook PC Bezel, for example), do not twist nor bend the TFT Module even momentary. At designing the enclosure, it should be taken into consideration that no bending/twisting forces are applied to the TFT Module from outside. Otherwise the TFT Module may be damaged.
- 12) Cold cathode fluorescent lamp in LCD contains a small amount of mercury. Please follow local ordinances or regulations for disposal.
- 13) Small amount of materials having no flammability grade is used in the LCD module. The LCD module should be supplied by power complied with requirements of Limited Power Source (IEC60950 or UL1950), or be applied exemption.
- 14) The LCD module is designed so that the CFL in it is supplied by Limited Current Circuit (IEC60950 or UL1950). Do not connect the CFL in Hazardous Voltage Circuit.
- 15) Severe temperature condition may result in different luminance, response time and lamp ignition voltage.
- 16) Continuous operating TFT-LCD display under low temperature environment may accelerate lamp exhaustion and reduce luminance dramatically.
- 17) The data on this specification sheet is applicable when LCD module is placed in landscape position.
- 18) Continuous displaying fixed pattern may induce image sticking. It's recommended to use screen saver or shuffle content periodically if fixed pattern is displayed on the screen.

## 2. General Description

This specification applies to the 8.4 inch color TFT LCD module G084SN03 V1.

This module is designed for display units for Industrial Applications.

The screen format is intended to support the SVGA (800(H) x 600(V)) screen and 16.2M (RGB 8-bits) or 262k colors (RGB 6-bits).

All input signals are LVDS interface compatible.

The module does not contain an inverter card for backlight.

This is an RoHS product.

### 2.1 Display Characteristics

The following items are characteristics summary on the table under 25 °C condition:

Items	Unit	Specifications
Screen Diagonal	[inch]	8.4 ( 213.4mm )
Active Area	[mm]	170.4(H) x 127.8(V)
Pixels H x V		800x3(RGB) x 600
Pixel Pitch	[mm]	0.213x 0.213
Pixel Arrangement		R.G.B. Vertical Stripe
Display Mode		TN, Normally White
Nominal Input Voltage VDD	[Volt]	3.3 typ.
Typical Power Consumption	[Watt]	3.3 typ.
Weight	[Grams]	215 ±10 (typ.)
Physical Size	[mm]	203.0(W) x 142.5(H) x 5.7(D) (typ.)
Electrical Interface		1 channel LVDS
Surface Treatment		Anti-glare, Hardness 3H
Support Color		262K(6-bit) / 16.2M(8-bit)
Temperature Range Operating Storage (Non-Operating)	[°C] [°C]	-30 to +85 (+85°C as panel surface temp.) -30 to +85
RoHS Compliance		RoHS Compliance

## 2.2 Optical Characteristics

The optical characteristics are measured under stable conditions at 25°C (Room Temperature):

Item	Unit	Conditions	Min.	Typ.	Max.	Note
White Luminance	[cd/m <sup>2</sup> ]	IRCFL= 4.6mA (center point)	200	220	-	1
Uniformity	%	9 Points	70	75	-	1, 2, 3
Contrast Ratio			400	600	-	4
Response Time	[msec]	Rising	-	10		5
	[msec]	Falling	-	25		
	[msec]	Raising + Falling	-	35		
Viewing Angle	[degree]	Horizontal (Right) CR = 10 (Left)	-	75	-	6
	[degree]		-	75	-	
	[degree]	Vertical (Upper) CR = 10 (Lower)	-	75	-	
	[degree]		-	75	-	
Color / Chromaticity Coordinates (CIE 1931)		Red x	TBD	TBD	TBD	
		Red y	TBD	TBD	TBD	
		Green x	TBD	TBD	TBD	
		Green y	TBD	TBD	TBD	
		Blue x	TBD	TBD	TBD	
		Blue y	TBD	TBD	TBD	
		White x	0.28	0.31	0.34	
		White y	0.30	0.33	0.36	
Color Gamut	%			45	-	

Note 1: Measurement method

Equipment Pattern Generator, Power Supply, Digital Voltmeter, Luminance meter (SR\_3 or equivalent)

Aperture 1° with 50cm viewing distance

Test Point Center

Environment < 1 lux

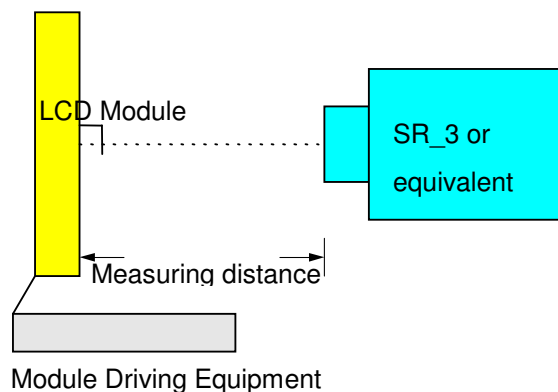

Note 2: Definition of 9 points position (Display active area : 170.4(H) x 127.8(V))

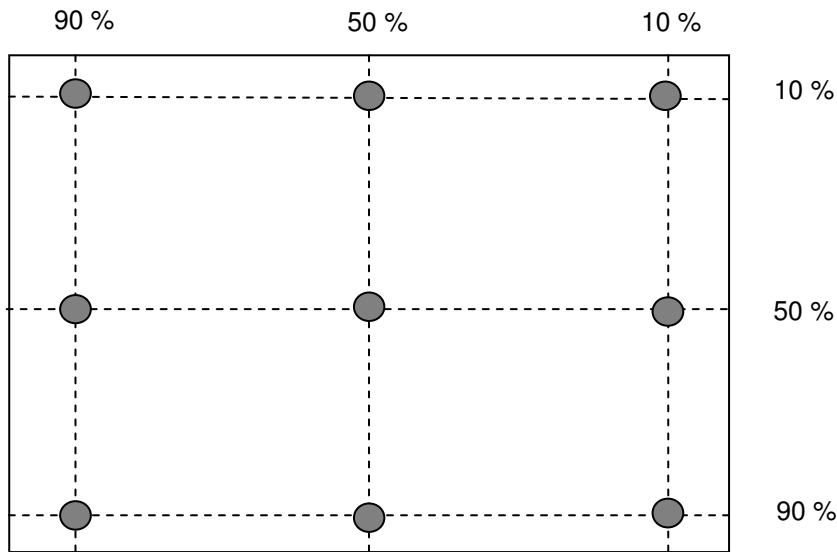

Note 3: The luminance uniformity of 9 points is defined by dividing the minimum luminance values by the maximum test point luminance

$$\delta_{w9} = \frac{\text{Minimum Brightness of nine points}}{\text{Maximum Brightness of nine points}}$$

Note 4 : Definition of contrast ratio (CR):

$$\text{Contrast ratio (CR)} = \frac{\text{Brightness on the "White" state}}{\text{Brightness on the "Black" state}}$$

Note 6: Definition of response time:

The output signals of photo detector are measured when the input signals are changed from "White" to "Black" (falling time) and from "Black" to "White" (rising time), respectively. The response time interval is between 10% and 90% of amplitudes. Please refer to the figure as below.

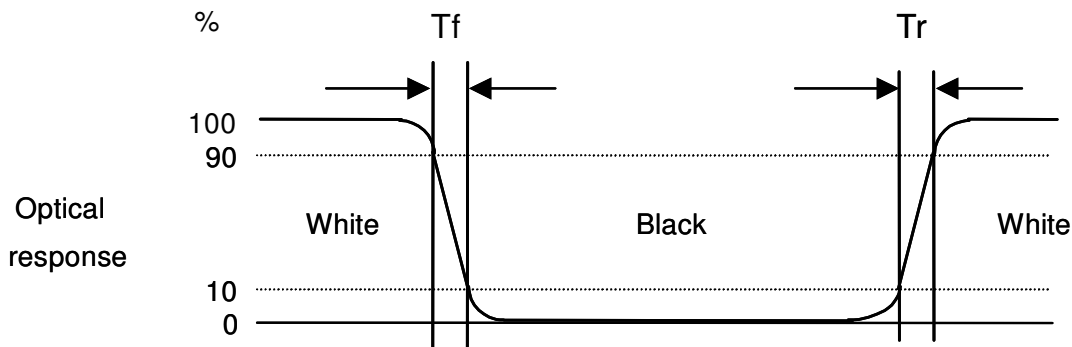

Note 7: Definition of viewing angle

Viewing angle is the measurement of contrast ratio  $\geq 10$ , at the screen center, over a 180° horizontal and 180°

vertical range (off-normal viewing angles). The 180° viewing angle range is broken down as below: 90° ( $\theta$ ) horizontal left and right, and 90° ( $\Phi$ ) vertical high (up) and low (down). The measurement direction is typically perpendicular to the display surface with the screen rotated to its center to develop the desired measurement viewing angle.

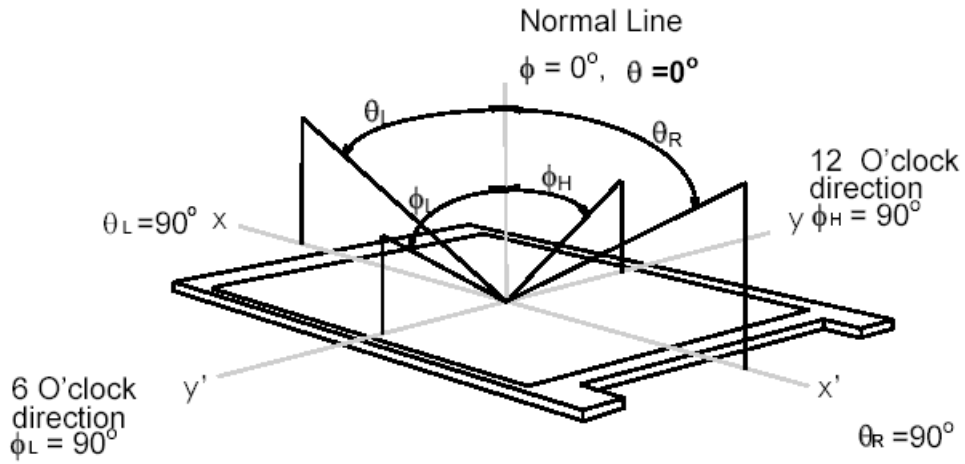



### 3. Functional Block Diagram

The following diagram shows the functional block of the 8.4 inch color TFT/LCD module:

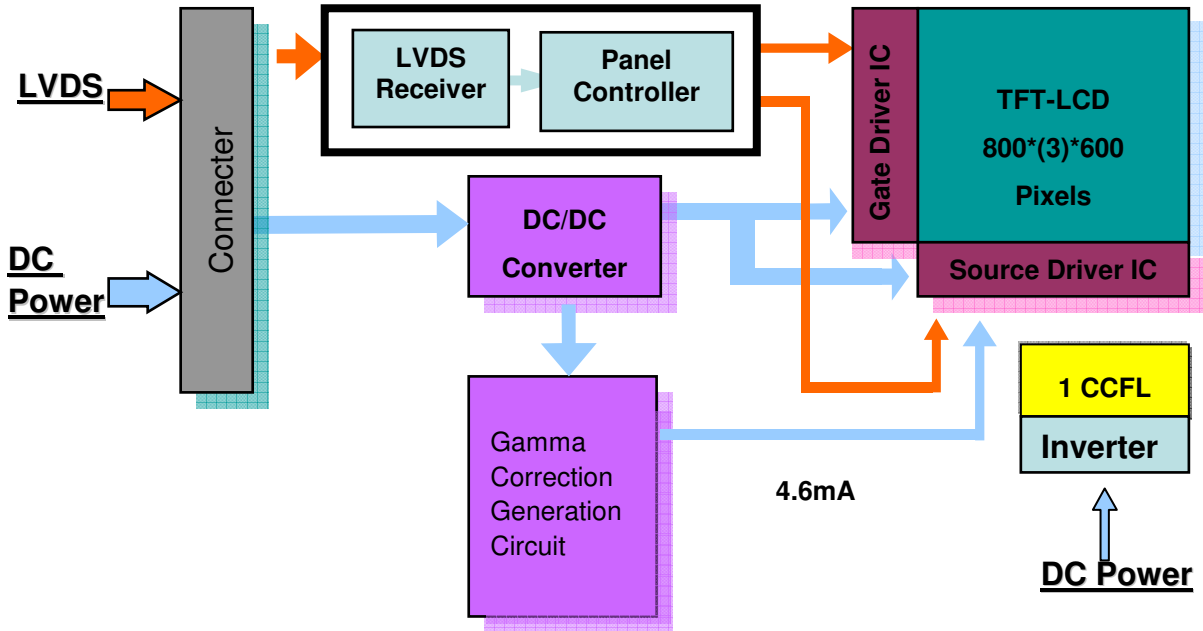

## 4. Absolute Maximum Ratings

### 4.1 Absolute Ratings of TFT LCD Module

Item	Symbol	Min	Max	Unit	Conditions
Logic/LCD Drive Voltage	Vin	-0.3	+3.6	[Volt]	
Input Voltage of Signal	Vin	-0.3	VDD+0.3	[Volt]	
CCFL Current	ICFL	4.1	5.1	[mA] rms	
CCFL Ignition Voltage	Vs	-	700	Vrms	25°C
			910		0°C

### 4.2 Absolute Ratings of Environment

Item	Symbol	Min	Max	Unit
Operating Temperature	TOP	-30	+85	[°C]
Operation Humidity	HOP	8	95	[%RH]
Storage Temperature	TST	-30	+85	[°C]
Storage Humidity	HST	5	95	[%RH]

Note: Maximum Wet-Bulb should be 39°C and no condensation.

## 5. Electrical Characteristics

### 5.1 TFT LCD Module

#### 5.1.1 Power Specification

Symbol	Parameter	Min	Typ	Max	Units	Remark
VDD	Logic/LCD Drive Voltage	3.0	3.3	3.6	[Volt]	± 10%
IDD	VDD Current	-	300	330	[mA]	64 Gray Bar Pattern (VDD=3.3V, at 60Hz)
Irush	LCD Inrush Current	-	-	3	[A]	Note 1
PDD	VDD Power	-	1	1.2	[Watt]	64 Gray Bar Pattern (VDD=3.3V, at 60Hz)

Note 1: Measurement condition:

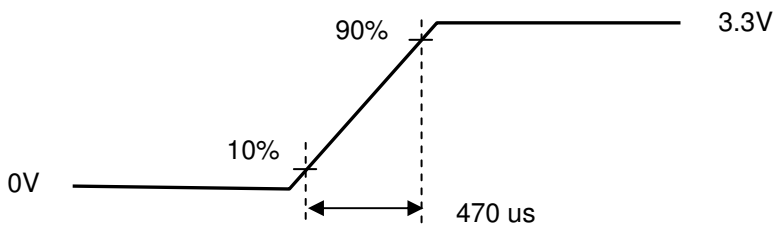
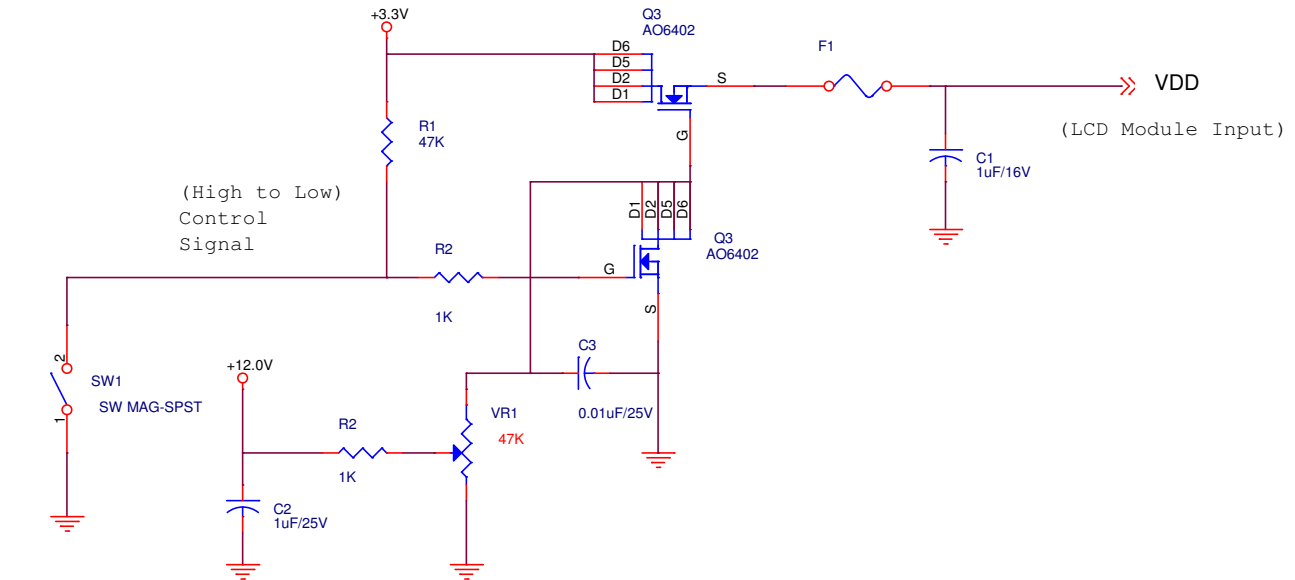

VDD rising time



64 Gray pattern

### 5.1.2 Signal Electrical Characteristics

Input signals shall be low or Hi-Z state when VDD is off.

Symbol	Item	Min.	Typ.	Max.	Unit	Remark
VTH	Differential Input High Threshold	-	-	100	[mV]	VCM=1.2V
VTL	Differential Input Low Threshold	-100	-	-	[mV]	VCM=1.2V
VID	Input Differential Voltage	100	400	600	[mV]	
VICM	Differential Input Common Mode Voltage	1.1		1.6	[V]	VTH/VTL=±100mV

Note: LVDS Signal Waveform.

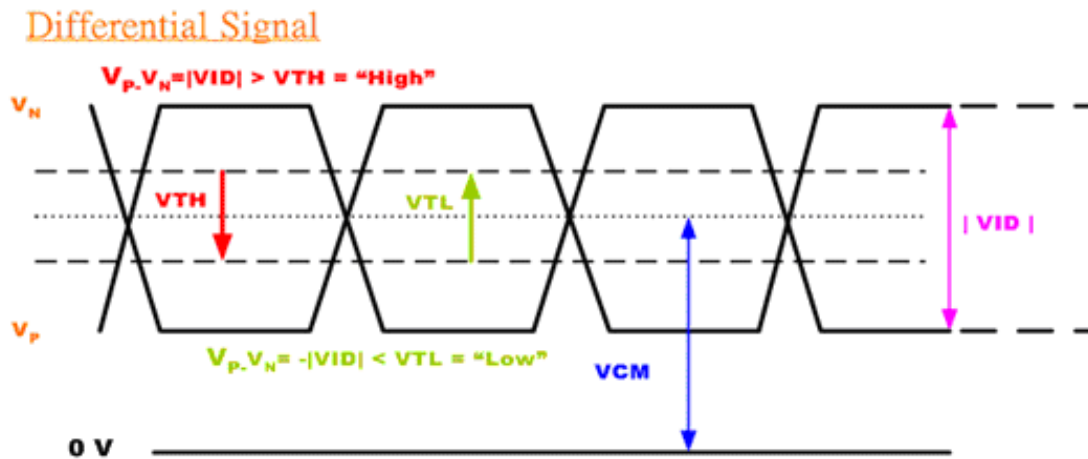

## 5.2 Backlight Unit

### 5.2.1 Parameter guideline for CCFL

Following characteristics are measured under a stable condition using an inverter at 25°C (Room Temperature):

Symbol	Parameter	Min.	Typ.	Max.	Unit	Remark
ICFL	CCFL operation range	4.1	4.6	5.1	[mA] rms	(Ta=25°C) Note 1
FCFL	CCFL Frequency	50	60	70	[KHz]	(Ta=25°C) Note 2
ViCFL (0°C) (reference)	CCFL Ignition Voltage	-	-	910	[Volt] rms	(Ta= 0°C)
ViCFL (25°C) (reference)	CCFL Ignition Voltage	-	-	700	[Volt] rms	(Ta=25°C)
VCFL	CCFL Discharge Voltage	441	490	539	[Volt] rms	(Ta=25°C) Note 3 IRCFL=4.6mA VCFL = Typ±10%
PCFL	CCFL Power consumption (inverter excluded)	1.81	2.25	2.75	[Watt]	(Ta=25°C) Note 3 IRCFL=4.6mA
Lamp Life		10,000	20,000	-	Hrs	(Ta=25°C) Note 4 IRCFL =4.6mA

Note 1: IRCFL is defined as the return current of an inverter. (In Figure. 1)

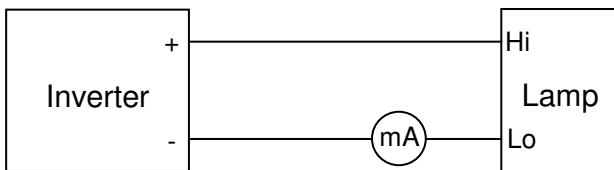

(Figure. 1: Measurement of return current)

A stable IRCFL is a current without flicker or biasing waveform provided by inverter that ensures the backlight perform to its specification. The ideal sine waveform should be symmetric in positive and negative polarities and the asymmetry rate of the inverter waveform should be below 10%.

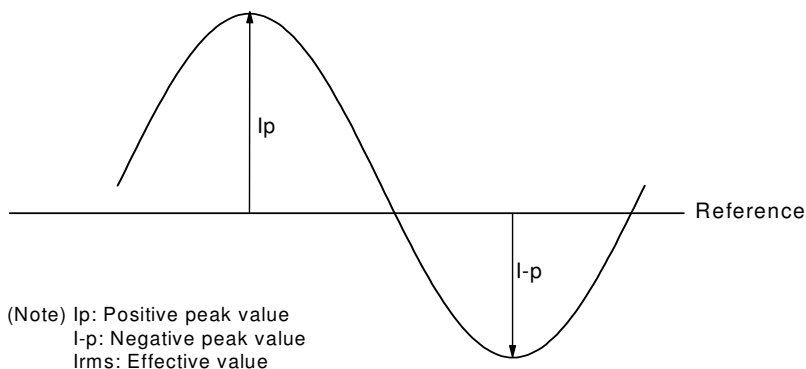

$$DC\ Bias = (|Ip - I-p| / I_{rms}) \times 100\% < 10\%$$

Crest Factor =  $I_p$  or  $(I-p) / I_{rms}$  should have the range within  $1.414 \pm 10\%$

It is recommended to use the inverter with detection circuit (ie: balance and protection circuit) to avoid overvoltage, overcurrent, or mismatching waveform.

Note 2: CCFL frequency should be carefully determined to avoid interference between inverter and TFT LCD. Higher frequency will induce higher leakage current and further impact lamp life.

Note 3: Calculator value for reference ( $IRCFL \times VCFL \times 1 = PCFL$ ).

Note 4: The definition of lamp life means when any of following conditions happen:

- a) Luminance falls to 50% or less of the initial value.
- b) Normal lighting is no more available (flickering, pink lighting, no lighting, etc.)
- c) Lamp voltage or lighting start voltage exceeds the specified value.

Lamp life time shortens according to

- a) Placing methodology: mercury is unevenly distributed in portrait mounting
- b) Environmental condition: low temperature reduces the presence of mercury vapor, which results in approximately lamp life of 1,000 hours
- c) CCFL surface temperature: Presence of gradient in lamp surface temperature causes uneven mercury migration
- d) Inverter design: its resonance capacitor should be fine-tuned with the impedance of CCFL
- e) Over driving current ( $> 5 \text{ mA}$ ) shortens lamp life time dramatically.

Note 5: The display is with dual lamp design, and the CCFL current in above table refers to each lamp

## 6. Signal Characteristic

### 6.1 Pixel Format Image

Following figure shows the relationship between input signal and LCD pixel format.

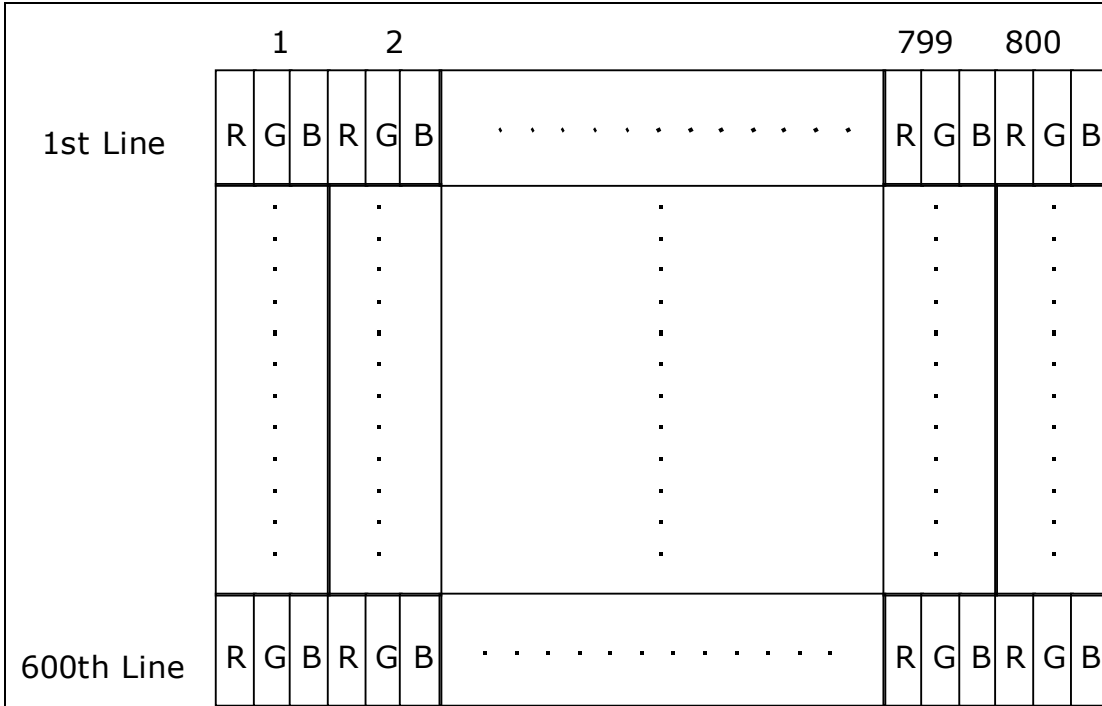

## 6.2 Scanning Direction

The following figures show the image seen from the front view. The arrow indicates the direction of scan.

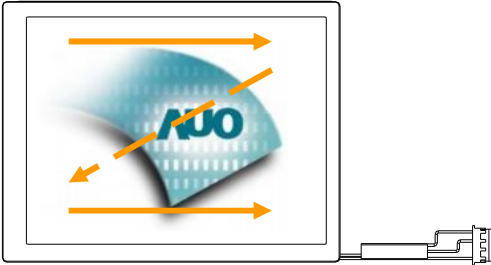

Fig. 1

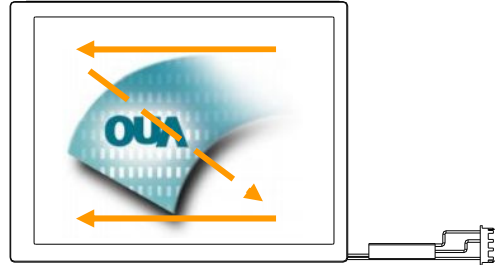

Fig. 2

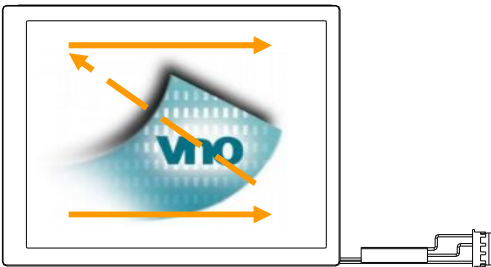

Fig. 3



Fig. 4

Fig. 1 Normal scan (Pin3, UD = Low or NC ; Pin4, RL = Low or NC)

Fig. 2 Reverse scan (Pin3, UD = Low or NC ; Pin4, RL = High)

Fig. 3 Reverse scan (Pin3, UD = High ; Pin4, RL = Low or NC)

Fig. 4 Reverse scan (Pin3, UD = High ; Pin4, RL = High)



### 6.3 Signal Description

LVDS is a differential signal technology for LCD interface and high speed data transfer device. The connector pin definition is as below.

Pin No.	Symbol	Description
1	VDD	Power Supply, 3.3V (typical)
2	VDD	Power Supply, 3.3V (typical)
3	UD	Vertical Reverse Scan Control, Low or NC → Normal Mode. High → Vertical Reverse Scan. <sup>Note</sup>
4	LR	Vertical Reverse Scan Control, Low or NC → Normal Mode. High → Vertical Reverse Scan. <sup>Note</sup>
5	RxIN0-	LVDS differential data input Pair 0
6	RxIN0+	
7	GND	Ground
8	RxIN1-	LVDS differential data input Pair 1
9	RxIN1+	
10	GND	Ground
11	RxIN2-	LVDS differential data input Pair 2
12	RxIN2+	
13	GND	Ground
14	RXCLKIN-	LVDS differential Clock input Pair
15	RXCLKIN+	
16	GND	Ground
17	SEL 68	LVDS 6/8 bit select function control, Low or NC → 6 Bit Input Mode. High → 8 Bit Input Mode. <sup>Note</sup>
18	NC	NC
19	RxIN3-	LVDS differential data input Pair 3. Must be tied to Ground in 6 bit input mode.
20	RxIN3+	

Note : "Low" stands for 0V. "High" stands for 3.3V. "NC" stands for "No Connected."

## 6.4 The Input Data Format

### 6.4.1 SEL68

**SEL68 = "Low" or "NC" for 6 bits LVDS Input**

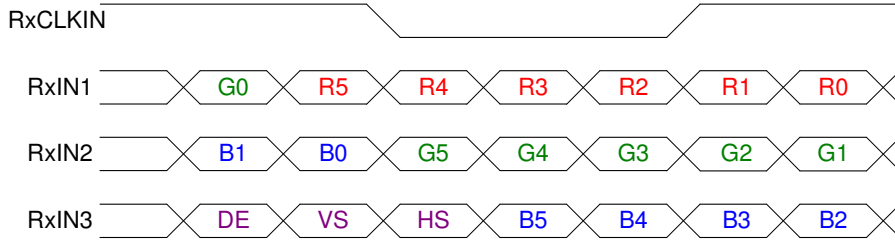

**SEL68 = "High" for 8 bits LVDS Input**

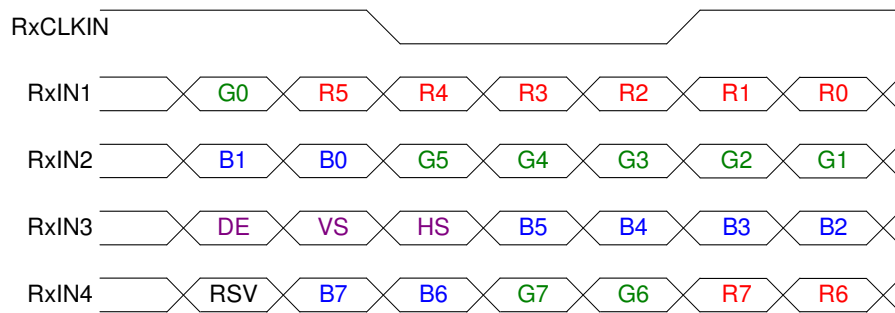

**Note1:** Please follow PSWG.

**Note2:** R/G/B data 7:MSB, R/G/B data 0:LSB

Signal Name	Description	Remark
R7	Red Data 7 (MSB)	Red-pixel Data Each red pixel's brightness data consists of these 8 bits pixel data.
R6	Red Data 6	
R5	Red Data 5	
R4	Red Data 4	
R3	Red Data 3	
R2	Red Data 2	
R1	Red Data 1	
R0	Red Data 0 (LSB)	
G7	Green Data 7 (MSB)	Green-pixel Data Each green pixel's brightness data consists of these 8 bits pixel data.
G6	GreenData 6	
G5	GreenData 5	
G4	GreenData 4	
G3	GreenData 3	
G2	GreenData 2	
G1	GreenData 1	
G0	GreenData 0 (LSB)	
B7	Blue Data 7 (MSB)	Blue-pixel Data Each blue pixel's brightness data consists of these 8 bits pixel data.
B6	Blue Data 6	
B5	Blue Data 5	
B4	Blue Data 4	
B3	Blue Data 3	
B2	Blue Data 2	
B1	Blue Data 1	
B0	Blue Data 0 (LSB)	
RXCLKIN+ RXCLKIN-	LVDS Clock Input	
DE	Display Enable	
VS	Vertical Sync	
HS	Horizontal Sync	

Note: Output signals from any system shall be low or Hi-Z state when VDD is off.

## 6.5 Interface Timing

### 6.5.1 Timing Characteristics

DE mode only

Parameter	Symbol	Min.	Typ.	Max.	Unit	Condition	
Clock frequency	$1/T_{\text{Clock}}$	33.6	39.8	48.3	MHz		
Vertical Section	Period	$T_V$	608	628	650	$T_H$	
	Active	$T_{VD}$	600	600	600		
	Blanking	$T_{VB}$	8	28	50		
Horizontal Section	Period	$T_H$	920	1056	1240	$T_{\text{Clock}}$	
	Active	$T_{HD}$	800	800	800		
	Blanking	$T_{HB}$	120	256	440		

### 6.5.2 Input Timing Diagram

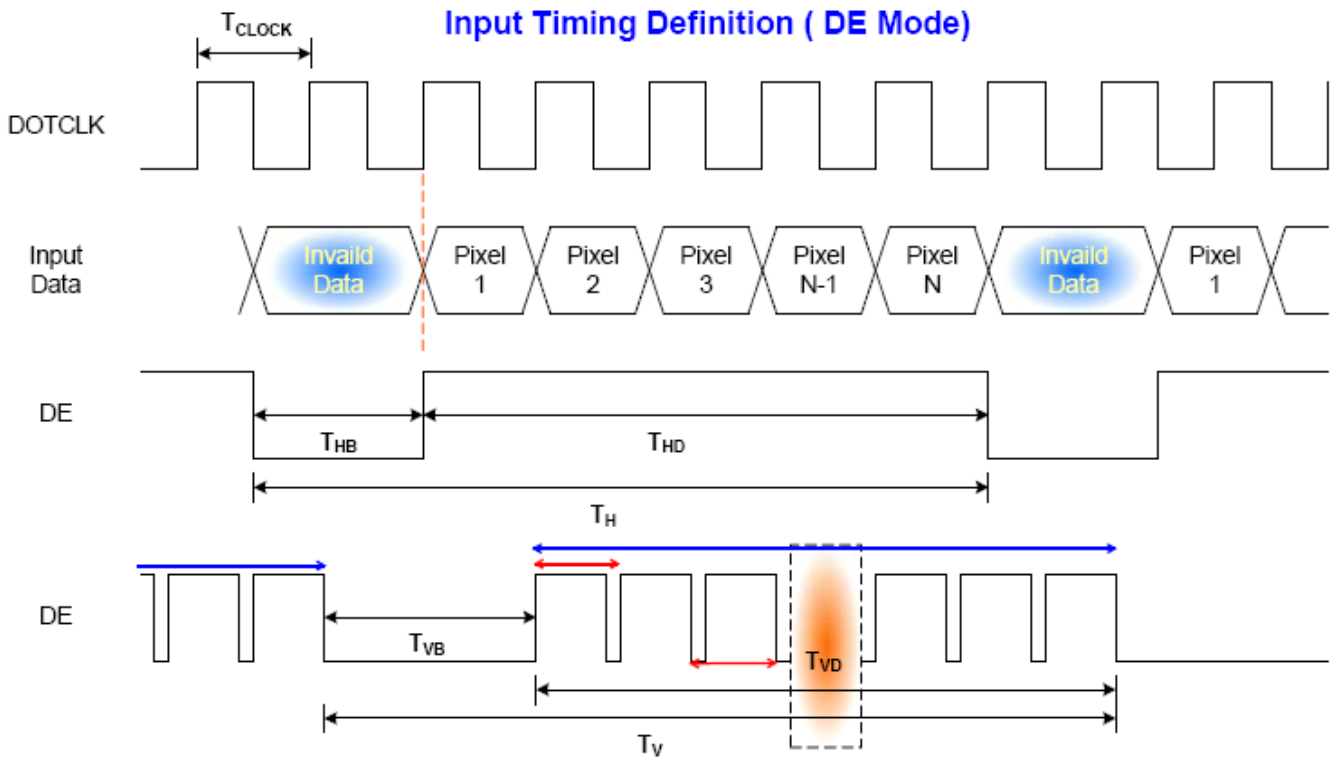

## 6.6 Power ON/OFF Sequence

VDD power and lamp on/off sequence is as below. Interface signals are also shown in the chart. Signals from any system shall be Hi-Z state or low level when VDD is off.

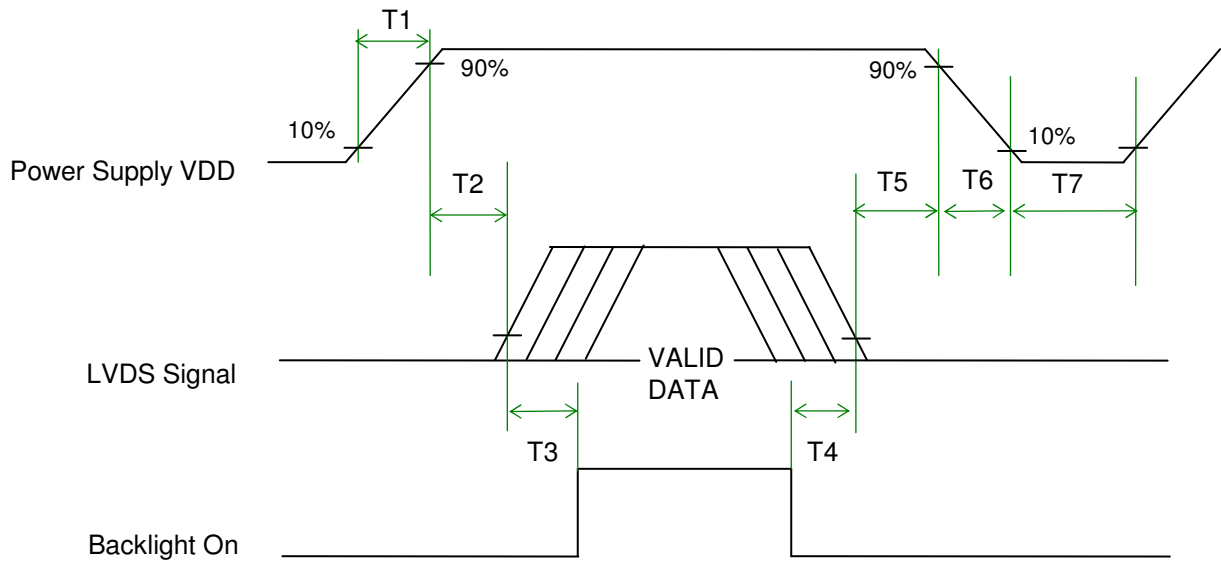

**Power ON/OFF sequence timing**

Parameter	Value			Units
	Min.	Typ.	Max.	
T1	0.5	-	10	ms
T2	0	40	50	ms
T3	200	-	-	ms
T4	200	-	-	ms
T5	0	16	50	ms
T6	0	-	10	ms
T7	1000	-	-	ms

The above on/off sequence should be applied to avoid abnormal function in the display. Please make sure to turn off the power when you plug the cable into the input connector or pull the cable out of the connector.

## 7. Connector & Pin Assignment

Physical interface is described as for the connector on module. These connectors are capable of accommodating the following signals and will be following components.

### 7.1 TFT LCD Module: LVDS Connector

<b>Connector Name / Designation</b>	<b>Signal Connector</b>
Manufacturer	STM
Connector Model Number	MSB24013P20 or compatible.
Adaptable Plug	P24013P20

Pin No.	Signal Name	Pin No.	Signal Name
1	VDD	2	VDD
3	UD	4	LR
5	RxIN0-	6	RxIN0+
7	GND	8	RxIN1-
9	RxIN1+	10	GND
11	RxIN2-	12	RxIN2+
13	GND	14	CKIN-
15	CKIN+	16	GND
17	SEL 68	18	NC
19	RxIN3+	20	RxIN3-

### 7.2 Backlight Unit: Lamp Connector

<b>Connector Name / Designation</b>	<b>Lamp Connector</b>
Manufacturer	JST
Connector Model Number	BHSR-02VS-1
Mating Model Number	SM02B-BHSS-1-TB

### 7.3 Lamp Connector Pin Assignment

Pin#	Symbol	Cable color	Signal Name
1	1	Pink	High voltage
2	2	White	Low voltage

- ◆ Cable length: 60 ± 5 mm
- ◆ Connector-output position: right side (front view)
- ◆ Lamp assembly design shall be easy for replacement and repair

## 8. Reliability Test Criteria

Items	Required Condition	Note
Temperature Humidity Bias	40°C /90%,500 hours	
High Temperature Operation	85°C ,300 hours	
Low Temperature Operation	-30°C ,300 hours	
Hot Storage	85°C ,300 hours	
Cold Storage	-30°C ,300 hours	
Thermal Shock Test	-20°C/30 min ,60°C/30 min ,100cycles	
Shock Test (Non-Operating)	50G,20ms,Half-sine wave,( ±X, ±Y, ±Z)	
Vibration Test (Non-Operating)	1.5G, (10~200Hz, P-P) 30 mins/axis (X, Y, Z)	
On/off test	On/10 sec, Off/10 sec, 30,000 cycles	
ESD	Contact Discharge: ± 8KV, 150pF(330Ω ) 1sec, 8 points, 25 times/ point Air Discharge: ± 15KV, 150pF(330Ω ) 1sec, 8 points, 25 times/ point	Note 1

Note1: According to EN61000-4-2, ESD class B: Some performance degradation allowed. No data lost  
 . Self-recoverable. No hardware failures.

## 9. Mechanical Characteristics

### 9.1 LCM Front View

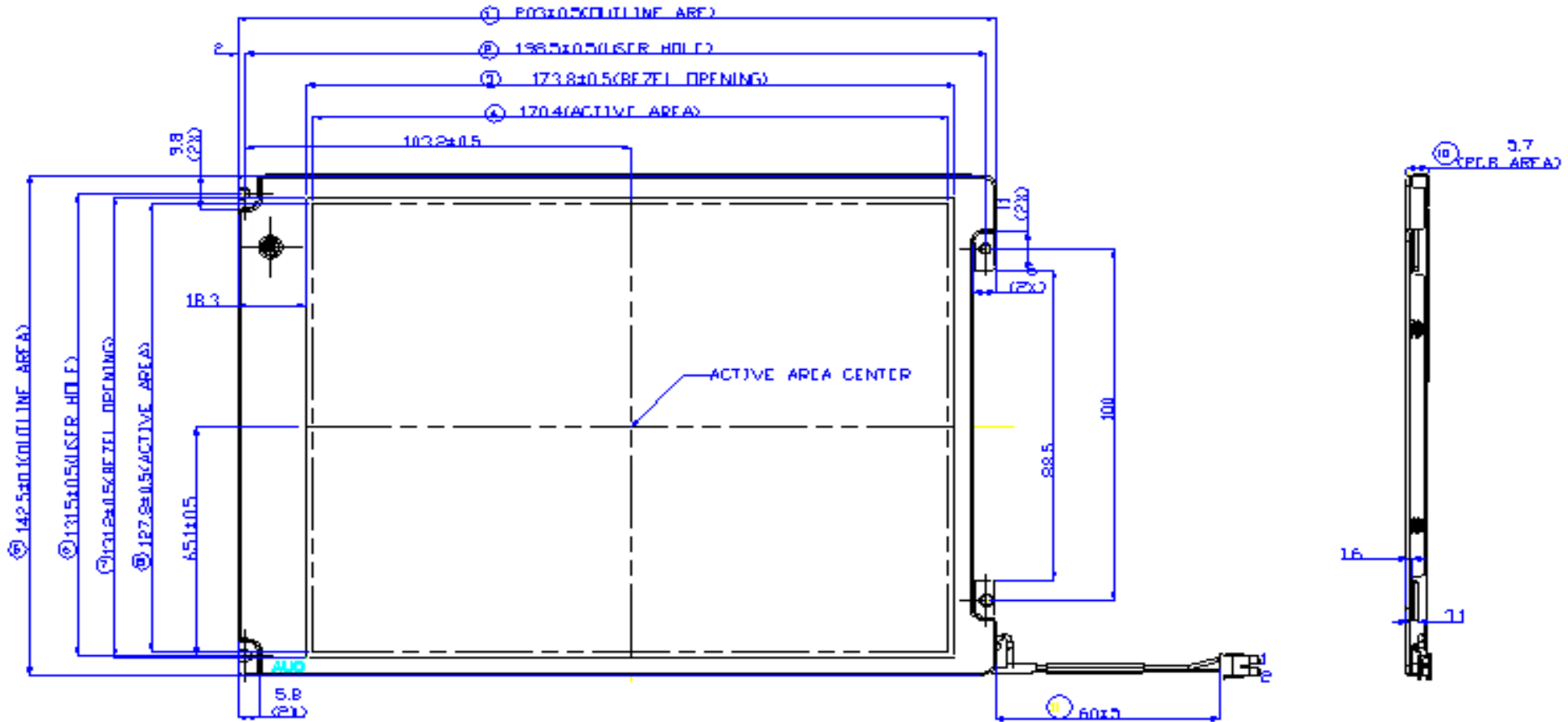

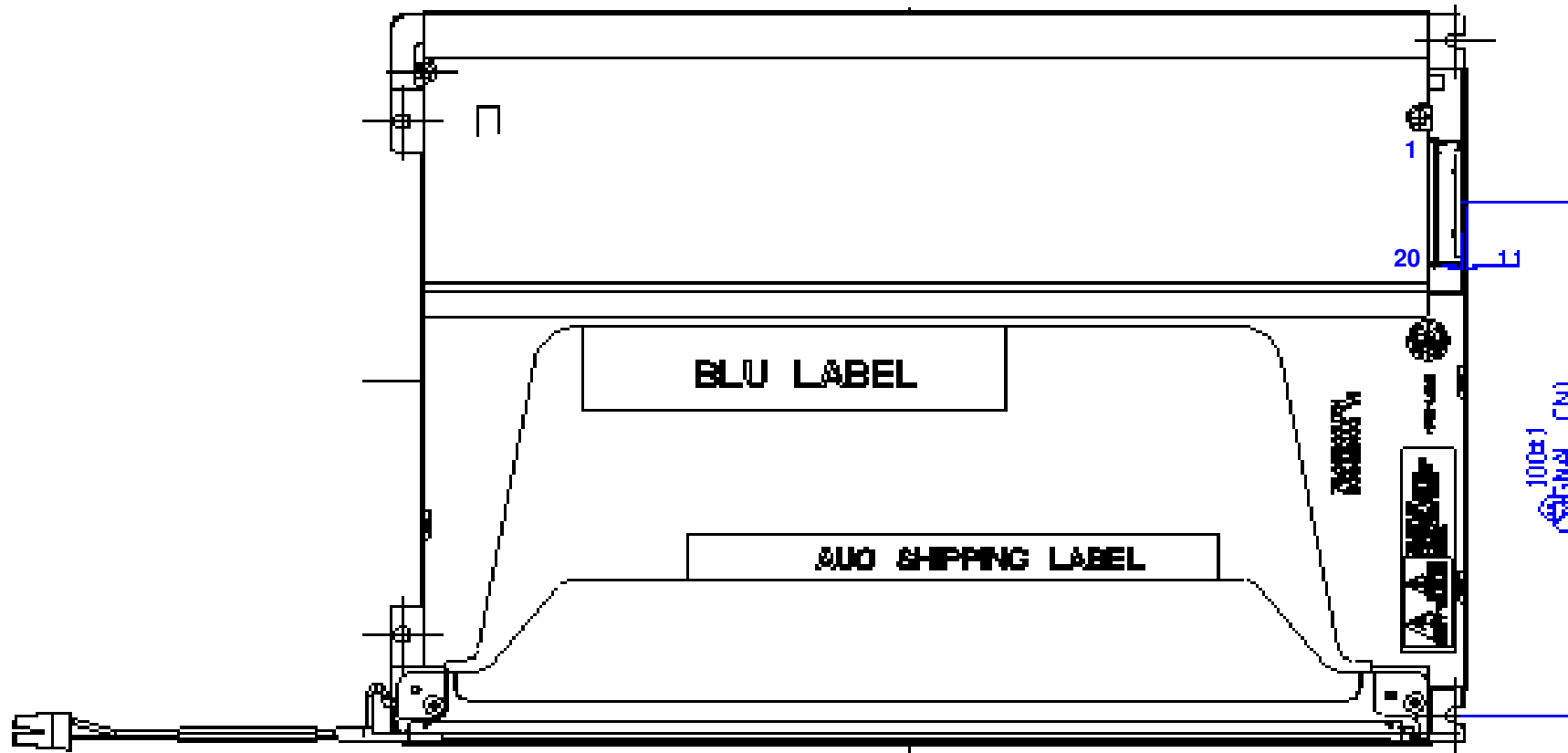





## 10. Label and Packaging

### 10.1 Shipping Label (on the rear side of TFT-LCD display)

TBD

### 10.2 Carton Package

TBD

## 11 Safety

### 11.1 Sharp Edge Requirements

There will be no sharp edges or comers on the display assembly that could cause injury.

### 11.2 Materials

#### 11.2.1 Toxicity

There will be no carcinogenic materials used anywhere in the display module. If toxic materials are used, they will be reviewed and approved by the responsible AUO toxicologist.

#### 11.2.2 Flammability

All components including electrical components that do not meet the flammability grade UL94-V1 in the module will complete the flammability rating exception approval process.

The pRxINted circuit board will be made from material rated 94-V1 or better. The actual UL flammability rating will be pRxINted on the pRxINted circuit board.

### 11.3 Capacitors

If any polarized capacitors are used in the display assembly, provisions will be made to keep them from being inserted backwards.

### 11.4 National Test Lab Requirement

The display module will satisfy all requirements for compliance to:

**UL 1950, First Edition**

U.S.A. Information Technology Equipment